

## Platinas de unión tipo pinza

Clamp-on couplings

Tourteaux d'accouplement a serrage rapide

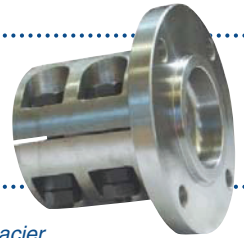

PLATOS  
TIPO PINZA

Platinas de unión tipo pinza, mecanizadas en acero F-114 / F-5, para ajuste cilíndrico al eje. Incluye tornillos y pasador de seguridad.

F-114 / F-5 steel clamp-on couplings. Key not required for easy installation and easy dismantling of the shaft assembly. Nuts and bolts are provided.

Tourteaux d'accouplement en acier F-114 / F-5 et de montage facile. Ces tourteaux n'ont pas besoin de rainures de clavettes. Les écrous et les vis sont fournis.

TIPO M / M-Type / Type M

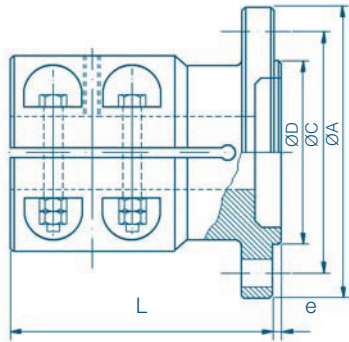

Øt

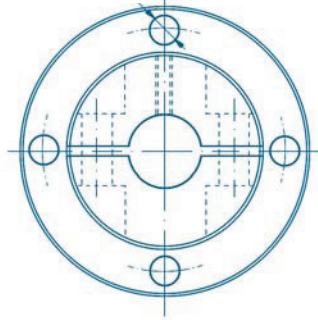

TIPO H / H-Type / Type H

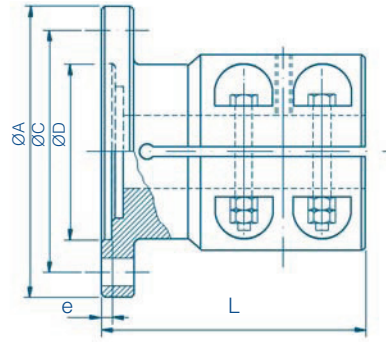

ØA = Ø Exterior / External Ø / Ø Exterieur  
 ØC = Ø Entre centros / Centre Ø dist. of axis / Ø Entraxe  
 ØD = Ø Encastre / Centre Ø / Ø Centrage  
 L = Longitud / Length / Longueur

e = Longitud de encastre / Centre length / Longueur de centrage  
 n = n° taladros / number of holes / nombre trous  
 Øt = Ø taladro / Ø hole / Ø trou

Ext. Ø A	Eje Shaft Arbre	REF.	Inversor Gear box Inverseur
100 mm.	20	910196	Volvo
	20	910112	Yanmar
	25	910197	Volvo
	30	911114	Volvo
	35	912115	Volvo
	25	910113	Yanmar
	30	910115	Yanmar
	35	912228	Yanmar
4 " (101,6 mm.)	20	910402	Borg-Warner V-Drive ZF - HURTH PRM - Newage Technodrive - Twindisc
	25	910401	
	30	911402	
	35	912403	
120 mm.	30	911208	Yanmar
	35	912209	Yanmar
	40	913209	Yanmar
125 mm.	30	911310	Yamaha
	35	912311	Yamaha
	40	913312	Yamaha
5 " (127 mm.)	30	911504	Borg-Warner V-Drive ZF - HURTH PRM - Newage Technodrive - Twindisc
	35	912505	
	40	913506	
130 mm.	35	912524	Yanmar
	40	913525	Yanmar
5 3/4" (146 mm.)	35	914524	Borg-Warner
	40	915525	IRM - ZF
	45	916526	HURTH - ZF
	50	917527	Twindisc MPM

Otras dimensiones y mecanizados en mm o pulgadas, según pedido.

Other dimensions and machining in mm or inches upon request.

D'autres dimensions dans mm et pouces en commande.

**IMPORTANTE:** Detallar el modelo del inversor-reductor, y la Relación de Transmisión (Ratio), ya que las dimensiones del plato pueden variar en función de estos datos.

**IMPORTANT:** Please specify the gear box ratio in order to know the correct flange dimensions.

**ATTENTION:** Détaillez le modèle de votre inverseur et la relation de transmission (Ratio), puisque les dimensions du tourteaux peuvent varier selon cette information.